



Owner's Guide

Dumbwaiter

Series 007

011

Congratulations on your choice of a Waupaca Elevator, Company, Inc., Dumbwaiter (W.E.C.).

Your dumbwaiter is manufactured in accordance with the National Elevator Codes.

Properly used and maintained, your new dumbwaiter will give you many years of excellent service.

This Owner's Guide should be reviewed periodically and saved for future reference.



We are a proud member of the Accessibility Equipment Manufacturers Association. This symbol assures you of our commitment to high quality and accessibility to everyone.

Table of Contents

Introduction	4
Serial Number	4
Maintenance and Service	4
Important Operating Warnings.....	5
Descriptive Features.....	6-7
Basic Operating Instructions.....	8
Troubleshooting	8
Limited Warranty	9

Note: The descriptions and specifications contained in this guide were in effect at the time the guide was approved for printing. Waupaca Elevator Company, Inc., reserves the right to discontinue models without notice and without incurring obligation. The equipment described within this guide may not be identified as either standard or optional and the various illustrations may not all be applicable to your particular unit. Always check with your Elevator Dealer if you have questions.

Your Dealer will instruct you on the proper and safe operation of your dumbwaiter. It is important that you read this *Owner's Guide* carefully before using your new dumbwaiter.

Your dumbwaiter was designed for years of dependable service. However, as with all electrical and mechanical equipment, proper operation and periodic maintenance are absolutely required. We recommend you establish a maintenance agreement with your dumbwaiter dealer.

Dumbwaiter Serial Number

This serial number contains specific information about your dumbwaiter, allowing technicians to properly identify replacement parts.

Maintenance and Service Dealer Information

Company: _____

Address: _____

Contact Name: _____













Telephone No. _____

If you have questions concerning the operation or maintenance requirements of your dumbwaiter, please contact the local dealer listed above. We suggest you develop an ongoing relationship with your dealer for routine servicing and periodic maintenance. Do not try to service or repair your dumbwaiter yourself.

Important Operating Warnings



Designates a condition where failure to follow instructions or heed warning could result in serious personal injury or death. When you see this symbol **HEED ITS MESSAGE**.

-  Anyone planning on using this dumbwaiter must be trained in its proper use and have read this owner's guide.
-  Do not allow unsupervised children to use this dumbwaiter!
-  Do not remove, bypass or alter various switches, controls and/or restraining devices. These are mandated by national and local safety codes. Any tampering could result in serious injury or death!
-  Never use your dumbwaiter as an elevator!
-  Never extend any body part or objects into your open hoistway... to do so could damage your dumbwaiter, cause serious injury or death!
-  Do not exceed maximum capacity of dumbwaiter (see car capacity plate).
-  Never open a gate, or hoistway door, while the dumbwaiter is in motion (it will stop the dumbwaiter).
-  If you detect a problem with your dumbwaiter, do not use it. Call your dealer immediately.
-  Do not use this dumbwaiter in the event of fire, smoke, flooding, or earthquake.
-  Keep your dumbwaiter clean and free of debris.
-  Observe, read and obey the warning labels, tags, and symbols, as they are provided by the manufacturer for your safety.
-  Safe operation requires a maintained hoistway temperature of between 60° - 110°F with a relative humidity not to exceed 95%. Do not expose electrical components to the elements or extreme temperature fluctuations. Resulting condensation will damage equipment, causing it to malfunction. If exposed, let sit for 12-24 hours prior to operation.

Assumption of Risk

ALL PERSONS who use this DUMBWAITER bear the responsibility for proper use of this product.

Misuse, deliberate or otherwise, voids all warranties... written or expressed!

Waupaca Elevator Company, Inc., is NOT responsible for any damage, injury or death resulting from improper installation, modification, additions or other changes which take place after the product has left the manufacturer's plant.

Descriptive Features

It is important that you familiarize yourself with the features of your W.E.C. Dumbwaiter before using.

Typical Gates

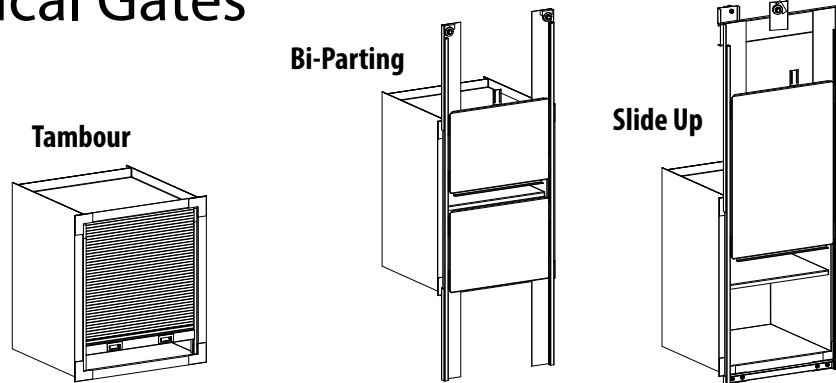

Hall Station

Hall Station will be located near the hoistway door.



- **“Floor or Up/Down” Button.** Press this button to call or send the car. The halo or back light will illuminate to acknowledge call and stay lit until arrival upon floor.
- **“Car Here” Indicator Light.** If present, this button will illuminate when the dumbwaiter has reached your floor.
- **Maintenance.** Clean your hall station plate with a clean cloth. Do not use harsh chemicals or abrasive cleaners.

Hoistway Door Interlock

The Hoistway Door Interlock locks the hoistway door when the car is not at that landing. Located inside the hoistway at the top corner on the latch side of the door jamb.

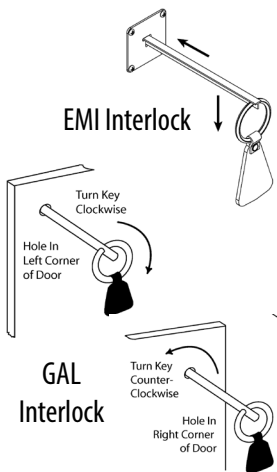

- **Emergency Key.** Can be used to open the door from outside the hoistway in case of emergency or for servicing. To unlock a door, insert the emergency release key into the hole (near the top of the door):

GAL Interlocks: Insert key and twist, while opening the door.

EMI Interlocks: Insert key and gently pull/press down on the key, while opening the door.

This key is not recommended for use in everyday operation of the dumbwaiter.

Descriptive Features

It is important that you familiarize yourself with the features of your new W.E.C. Dumbwaiter before using.



HG-1 Keylock (Optional)

Disengage the HG-1 Keylock by inserting the key, turning and pulling lock outward until gate opens. Lock the gate by pushing lock mechanism back into place, turning and then removing key.



Lantern & Chime

Upon arrival Lantern illuminates and chimes once.

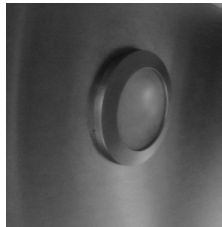

Car Light (Optional)

Illuminates when the car gate is open.

Basic Operating Instructions

- **Press the “Floor or Up/Down” Button.** This will call the dumbwaiter to your floor.
- **Open the Hoistway Door.** Open the door once the dumbwaiter has come to a complete stop at your floor.
- **Open the Gate.**
- **Load/Unload the Dumbwaiter.**
- **Close the Gate and Hoistway Door.** The dumbwaiter will not operate unless the gate and the entry door are both completely closed.
- **Press the “ Floor or Up/Down” Button.** Send the dumbwaiter to the floor of your choice.
- **Complete Stop.** Wait for the dumbwaiter to come to a complete stop.
- **Open the Hoistway Door and Gate.**
- **Load/Unload the Dumbwaiter.**
- **Close Gate and Hoistway Door.** Completely close both the gate and the entry door of the dumbwaiter. The dumbwaiter will not respond to another call if either the gate or the entry door is not completely closed.

Troubleshooting

Before Calling for Service...

Check to see if you press the call button and hear the buzzer/bell. This signals a hoistway door or gate is open.

Verify that all gates and doors are securely closed by opening and closing them. The dumbwaiter will not operate when a gate or door is partially open.

Verify the disconnect switch is in the “ON” position.

Wait 7 seconds between calls.

Do not attempt to repair the dumbwaiter yourself.

If your dumbwaiter still does not function call your dealer immediately.

LIMITED WARRANTY

Product _____ **Serial Number** _____

Warranty to Original End User: Waupaca Elevator Company, Inc. (Waupaca) warrants to the original end user that its products are free from defects in materials and workmanship under normal use and service. This warranty extends for **three (3)** years from the date the product is shipped from our factory, except for an extended **five (5)** year warranty for the components specifically listed below. THIS WARRANTY APPLIES ONLY TO THE ORIGINAL END USER AND IS NOT TRANSFERABLE.

Extended Warranty Period for Certain Components: Waupaca warrants the following components for **five** years: buffers, cable clamps, cams, drum, hydraulic cylinder, limit switches, Mitsubishi drive, pedestal, pedestal base, pulleys, rail, rail brackets, shackles, sling, travel cable.

What the Warranty Covers:

Waupaca's entire liability under this warranty is limited to the repair or replacement in kind of any defective product or component within the term of this warranty, as Waupaca in its sole discretion determines and deems appropriate. No oral or written information or advice given by Waupaca, its distributors, agents or employees shall create any different or additional warranties or in any way increase the scope of this warranty.

This warranty does not cover labor charges for the removal, repair, or replacement of warranty parts unless specifically authorized in advance by Waupaca. All warranty service work must be performed by an authorized Waupaca service technician.

Revocation and Nullification of Warranty: Waupaca's warranty is null and void if the product is not inspected and serviced by a Waupaca authorized service representative at least annually. In addition, the warranty will be revoked and nullified with respect to the following claims:

1. Claims resulting from normal wear and tear, including batteries, panels, gates, glass, acrylic, trim, and consumable parts.
2. Claims resulting from abuse, misuse, or alteration or modification of the product or any component thereof.
3. Claims that are due to a failure to install, maintain, lubricate, inspect and maintain the product in accordance with Waupaca's instructions, and verified by written records of all inspections and maintenance.
4. Claims resulting from maintenance, repairs, or replacement performed by anyone other than a Waupaca authorized service technician.
5. Claims resulting from malfunction or damage caused by vandalism, a structural condition of the building or hoistway, overloading, and Acts of God.

Waupaca Dealers;

Any defective parts covered by this warranty should be returned to Waupaca, after first contacting Waupaca for a return shipping authorization and RMA Number, and mailing to the following address:

Waupaca Elevator Company, Inc.
1726 North Ballard Road, Suite 1
Appleton, WI 54911
(800) 238-8739

THIS WARRANTY IS THE ONLY WARRANTY APPLICABLE TO OUR PRODUCTS AND IS IN LIEU OF ALL OTHER WARRANTIES AND LIABILITIES, EXPRESSED OR IMPLIED. WAUPACA EXPRESSLY EXCLUDES AND DISCLAIMS ANY IMPLIED WARRANTIES OF MERCHANTABILITY OR FITNESS FOR A PARTICULAR PURPOSE, AND SHALL NOT BE LIABLE FOR INCIDENTAL OR CONSEQUENTIAL DAMAGES OF ANY NATURE, INCLUDING WITHOUT LIMITATION, LOST PROFITS, REVENUES, OR PRODUCTIVITY, OR FOR BODILY INJURY OR DEATH OR LOSS OR DAMAGE TO PROPERTY, UNDER ANY THEORY OF LIABILITY, INCLUDING WITHOUT LIMITATION, CONTRACT, WARRANTY, STRICT LIABILITY, TORT (INCLUDING NEGLIGENCE) OR OTHER LEGAL OR EQUITABLE THEORY.

Notes:

PM0003-D
16 OCT 2015

1726 North Ballard Road, Suite 1 • Appleton, WI 54911
Phone 920-991-9082 • www.waupacaelevator.com

